

Manual for Charging Rectifier type PRX3



SAFETY INSTRUCTIONS



This manual must be read **before** installation, use or work on the product.



This product contains dangerous voltages that when touched can cause electric shock, burns or death.

The product must be installed by qualified personnel and according to the installation instructions. Service may only be performed by authorized service personnel. The protective covers and contact safety devices inside the equipment may only be removed by authorized service personnel.

The power must always be disconnected in a safe way before starting any service/maintenance.



Warning for reverse voltage. Power is supplied from several sources.

Manual: 9-1636-A
P/n: 0001085

We reserve the right to make changes to the content of this manual without prior notification.

CONTENTS

1	PRESENTATION.....	4
2	SAFETY INSTRUCTIONS.....	5
3	TECHNICAL DATA	6
3.1	ASSORTMENT	6
3.2	Electrical data	6
3.2.1	Electrical input data	6
3.2.2	Electrical output data	6
3.3	ENVIRONMENTAL DATA.....	7
3.4	MECHANICAL DATA.....	7
3.5	CONFORMITY WITH STANDARDS	7
4	FUNCTIONAL DESCRIPTION.....	8
4.1	GENERAL.....	8
4.2	RECTIFIER MODULES.....	8
4.2.1	General.....	8
4.2.2	Maneuvering and indications.....	8
4.2.3	Voltage control	8
4.2.4	Current control	9
4.2.5	Temperature control	9
4.2.6	Output power control	9
4.2.7	Fan speed control	9
4.2.8	Loadsharing	9
4.2.9	Overvoltage DC (HVSD).....	9
4.2.10	Over-/Undervoltage AC.....	10
4.2.11	External blocking	10
4.2.12	Hot swap	10
4.3	FUNCTIONS OF COMPLETE CHARGING RECTIFIER	10
4.3.1	General.....	10
4.3.2	Float charging.....	10
4.3.3	Equalizing charging	10
4.3.4	Battery circuit test	11
5	OPERATION	12
5.1	GENERAL.....	12
5.2	RECTIFIER MODULES.....	12
5.2.1	General.....	12
5.2.2	Manoeuvre	12
5.2.2.1	ON.....	12
5.2.2.2	STBY (standby)	12
5.2.3	Indications	12
5.2.3.1	AC OK	12
5.2.3.2	DC OK.....	13
5.2.3.3	ALARM	13
5.2.3.4	CURRENT	13
5.2.3.5	Indication table.....	13
5.3	MONITORING UNIT PCM2	13
6	INSTALLATION INSTRUCTIONS.....	15
6.1	SAFETY INSTRUCTIONS.....	15
6.2	GENERAL.....	15
6.3	STORAGE AND PROTECTION	15
6.4	MOUNTING.....	15
6.4.1	General.....	15
6.4.2	Erection of cubicle.....	15

6.4.2.1	Cubicle type F27	15
6.4.2.2	Cubicle type F41	16
6.4.2.3	Cubicle type S39.....	16
6.4.3	Mounting of rectifier modules.....	16
6.4.3.1	General.....	16
6.4.3.2	Cubicle type F27 and F41	16
6.4.3.3	Cubicle type S39.....	17
6.5	ELECTRICAL INSTALLATION.....	17
6.5.1	General.....	17
6.5.2	Grounding.....	17
6.5.3	Mains voltage	17
6.5.4	DC power output.....	18
6.5.5	I/O unit.....	18
6.5.6	Rectifier modules.....	18
6.5.6.1	Cubicle type F27 and F41	18
6.5.6.2	Cubicle type S39.....	19
7	COMMISSIONING	20
7.1	SAFETY INSTRUCTIONS.....	20
7.2	PREPARATORY INSPECTION	20
7.3	POWERING UP	20
7.3.1	DC.....	20
7.3.2	AC	20
7.4	CHECKING THE CHARGING VOLTAGE.....	21
7.5	CHECKING THE SETTINGS	21
7.6	CHECKING THE OUTPUTS.....	21
8	MAINTENANCE.....	22
8.1	ANNUAL INSPECTION.....	22
8.1.1	General.....	22
8.1.2	Checking the charging voltage.....	22
8.1.3	Checking the cooling capacity.....	22
9	FAULT TRACING AND SERVICE.....	23
9.1	SAFETY INSTRUCTIONS.....	23
9.2	FAULT TRACING ALARMS	23
9.3	OTHER FAULT TRACING	23
9.4	INSTRUCTIONS FOR REPLACING RECTIFIER MODULE DURING OPERATION (HOT SWAP)	24
9.4.1	Enclosure type F27 and F41	25
9.4.2	Enclosure type S39	25

Appendices

- [A LAYOUT AND DIMENSION DIAGRAM PRX3, CUBICLE TYPE F27](#)
- [B LAYOUT AND DIMENSION DIAGRAM PRX3, CUBICLE TYPE F41](#)
- [C LAYOUT AND DIMENSION DIAGRAM PRX3, CUBICLE TYPE S39](#)
- [D DIMENSION DIAGRAM RECTIFIER MODULE PRM3](#)
- [E CIRCUIT DIAGRAM PRX3](#)
- [F CIRCUIT DIAGRAM RECTIFIER MODULE PRM3](#)

1 PRESENTATION

PRX3 is a complete modular charging rectifier for total output power up to 54 kW.

The main parts of the system are 3-phase rectifier modules type PRM3 working in parallel aimed for mounting in 19" cabinet, monitoring unit type PCM2 specially designed for DC systems and also fuses and disconnectors for highest safety and easy service and maintenance.

The rectifier modules can be connected in parallel for flexible adaption of output power and the possibility of redundancy. They can also be swapped during operation (hot swap) with easy maintenance and high availability as a result. Fans with speed control and monitoring gives low noise levels. This, together with the clear display and well-arranged system of menus of the monitoring unit makes it easy and pleasant to work with.

This description primarily deals with all installation, commissioning, service, maintenance and technical data and is principally aimed at the personnel who are responsible for these areas. Equivalent descriptions of the parts of the equipment that relate to the monitoring unit are detailed in the *Manual for monitoring unit type PCM2*.

Operation is handled primarily via the monitoring unit described in the *Manual for monitoring unit type PCM2*. This is therefore chiefly aimed at the personnel that have the day to day responsibility for the plant, but also to other personnel who have cause to work with the D.C. system.

For a complete description, this manual is to be used together with the description for the monitoring unit, *Manual for monitoring unit type PCM2*.

The term "charging rectifier" is replaced henceforth with the shorter term "rectifier".

2 SAFETY INSTRUCTIONS



This product contains dangerous voltages that when touched can cause electric shock, burns or death.

For safety reasons the concerned personnel are classified according to the following requirements for specific skills.

Authorised service personnel:

- Have electrical training and adequate experience to avoid the dangers that electricity can cause.
- Are certified to meet authority requirements for the work in question.
- Have linguistic skills that ensure that the content of this description cannot be misunderstood.
- Have undergone a product-specific training programme for authorised service personnel that are approved by Kraftelektronik AB.

Qualified personnel:

- Have electrical training and adequate experience to avoid the dangers that electricity can cause.
- Are certified to meet authority requirements for the work in question.
- Have linguistic skills that ensure that the content of this description cannot be misunderstood.

Installation, service, maintenance and fault tracing may only be carried out by authorised personnel and in accordance with the installation instructions.

The protective covers and contact safety devices inside the equipment may only be removed by authorised service personnel.

Rectifier modules may only be opened by authorised service personnel.

3 TECHNICAL DATA

3.1 ASSORTMENT

Model PRX3	Output data					Input data				Power loss**	Rect. module		Cubicle/weight		
	U _{NOM}	U _{MAX*}	I _{RATED}	Output power	Terminal	Mains power*	Mains current*	Mains fuse	Terminal		Number	I _{RATED}	F27	F41	S39
	V _{DC}	V _{DC}	A	kW	mm ²	kVA	A _{rms}	A _{gL/gG}	mm ²			A	kg	kg	kg
110/70	110	145	70	9	50	10.6	18	25	16	0.7	1	70	90	90	190
110/140			140	18	95	21.2	36	50	16	1.4	2		110	110	210
110/210			210	27	150	31.8	54	63	35	2.2	3		-	130	230
110/280			280	36	240	42.4	72	80	35	2.9	4		-	-	250
110/350			350	45	2x150	53.0	90	100	50	3.6	5		-	-	270
110/420			420	54	2x240	63.6	108	125	95	4.3	6		-	-	290
220/36	220	270	36	9	35	10.6	18	25	16	0.7	1	36	90	90	190
220/72			72	18	50	21.2	36	50	16	1.4	2		110	110	210
220/108			108	27	95	31.8	54	63	35	2.2	3		-	130	230
220/144			144	36	95	42.4	72	80	35	2.9	4		-	-	250
220/180			180	45	2x150	53.0	90	100	50	3.6	5		-	-	270
220/216			216	54	2x150	63.6	108	125	95	4.3	6		-	-	290
440/18	440	500	18	9	35	10.6	18	25	16	0.7	1	18	90	90	190
440/36			36	18	35	21.2	36	50	16	1.4	2		110	110	210
440/54			54	27	50	31.8	54	63	35	2.2	3		-	130	230
440/72			72	36	50	42.4	72	80	35	2.9	4		-	-	250
440/90			90	45	50	53.0	90	100	50	3.6	5		-	-	270
440/108			108	54	95	63.6	108	125	95	4.3	6		-	-	290

* maximum at 3x340 V_{AC}** type at 3x400 V_{AC} and full load

3.2 Electrical data

3.2.1 Electrical input data

Rated voltage380/400 V_{AC} 3-phase, TN network
 Input voltage range340-440 V_{AC}
 Overvoltage protection> 580 V_{AC}, rectifier module stops
 Undervoltage protection< 300 V_{AC}, rectifier module stops
 Frequency45 – 65 Hz
 Power factor.....> 0.97 (at 3x400 V_{AC}, full load)

Other, see table in section 3.1 [ASSORTMENT](#).

3.2.2 Electrical output data

Voltage regulation (static).....<±0.5 % of nominal output voltage
 Voltage regulation (dynamic)<±1 % within 3 sec, 0-100 / 100-10 % load change
 Current regulation<±1 % of rated current
 Setting range, current limit0 – 100 % of rated current
 Ripple voltage<0.2 %_{RMS}
 Ripple current<1 % of rated current
 Efficiency, typical.....>92 % at 3x400 V_{AC}

Other, see table in section 3.1 [ASSORTMENT](#).

3.3 ENVIRONMENTAL DATA

Class of enclosure	IP21 as per EN 60529
Cooling	Temperature controlled fans in rectifier modules, otherwise natural convection
Ambient temperature	0 to +40 °C
Storage temperature	-40 to +70 °C
Humidity	<90 % RH, non-condensed
Altitude a.s.l	<2000 m
Noise level at +20 °C, 25% load	50-58 dBA depending on number of rectifier modules

3.4 MECHANICAL DATA

Design	Floor cabinet with 19" rack frame
Placement	Standing on floor indoors in dry and clean area
Weight	See table in section 3.1 ASSORTMENT .
Dimensions	Cubicle type F27: 1361/600/600 mm (h/w/d), Cubicle type F41: 2053/600/474 mm (h/w/d), Cubicle type S39: 2100/840/654 mm (h/w/d), see also layout drawing Appendix A
Colour	RAL 7035 light grey
Cable inlet	From above or beneath (F27, F41) From beneath, above as option (S39)

3.5 CONFORMITY WITH STANDARDS

EN 60529	Protection degree IP21
EN 50178	LVD. Electronic equipment, including power electronics in electrical power installations.
EN 50272-2	Safety requirements for secondary batteries and battery installations
EN 61000-6-2	EMC. Immunity of equipment in an industrial environment
EN 61000-6-4	EMC. Emission from equipment in an industrial environment

4 FUNCTIONAL DESCRIPTION

4.1 GENERAL

PRX3 is a complete charging rectifier equipped with up to six rectifier modules of the type PRM3 working in parallel with three-phase mains power feeding. The monitoring unit PCM2 is built in for monitoring of both rectifiers, battery and other parts of the complete DC system. For each rectifier module there are fuse links for both AC and DC that can be used as disconnection for safe and easy maintenance and service.

Most of the function is associated with the monitoring unit which is described in the *Manual for monitoring unit PCM2*. Only functions added on rectifier system level are discussed in this section.

4.2 RECTIFIER MODULES

4.2.1 General

Only functions related to the rectifier module itself are specified here. For information about general functions, see the *Manual for monitoring unit PCM2*.

4.2.2 Maneuvering and Indications

The front panel holds pushbuttons for maneuvering and a number of indication lamps.

There is no built-in mains breaker in the module. Instead, there is an ON-button and a STBY-button, where STBY means that the module is turned off by being put into a standby mode. The ON and STBY states are saved in a non-volatile memory which means that even after a total main outage, the module will return to the state that was present at the moment of the outage.



For detailed description of the front panel functions, see section 5 [OPERATION](#).

4.2.3 Voltage control

At normal operation, the rectifier module will regulate the output voltage according to a setpoint provided by the monitoring unit.

The voltage reported from the module to the monitoring unit is measured on the “inside” of the modules output blocking diode. Due to the diode voltage drop, it will therefore be slightly higher than expected. The difference is dependent of the output current, but its size is about 1 V. The output voltage however, will always be correct because the monitoring unit measures the voltage directly in the battery distribution board. By regulation of the setpoint, voltage drop in both output diode and cables are compensated.

In case of an interruption of the communication between the module and the monitoring unit, the module will continue with the last valid setpoint.

After a cold-start of a rectifier module, it will begin with nominal voltage (110, 220, 440V) until the communication with the monitoring unit is established.

In the monitoring unit there is a parameter holding the level for the overvoltage protection (HVSD). No matter the level of the requested setpoint, the output voltage of the module will be limited to maximum 1% below existing HVSD level.

4.2.4 Current control

At normal operation the rectifier module will regulate according to the setpoint (current limit) provided from the monitoring unit.

The current limit is also used as a tool for the functions temperature control, power control and load sharing.

4.2.5 Temperature control

To protect the rectifier module from overheating, the current limit is lowered gradually as the internal temperature gets close to a critical level. Should the temperature after all rise above the critical level, the module will turn off and be kept turned off until the temperature has fallen to a reasonable level. Meantime the cooling fans will run at full speed.

4.2.6 Output power control

At high output voltages, the output power will be limited to rated power by lowering the current limit.

4.2.7 Fan speed control

In order to reduce the noise level to a minimum and to extend the lifetime of the fans, the fan speed is regulated by the internal temperature of the module. The fan speed is continuously monitored in order to provide an early warning if any of the three fans shows sign of being worn out. Note that the fans by design are meant to last for the whole lifetime of the module.

Directly after start the cooling fans are working at full speed for about half a minute before speed controlled by temperature begins.

At stop the cooling fans continues to run for about half a minute in order to cool off the remaining heat.

4.2.8 Loadsharing

In the PRX3 up to 6 rectifiers can be working in parallel while sharing the load using so called active loadsharing. The loadsharing is active in the range of about 10 – 90 % of the rated current.

During loadsharing, the first rectifier module acts as a master. The loadsharing will therefore change from active to passive mode if that particular module is turned off or is out of order.

4.2.9 Overvoltage DC (HVSD)

In order to protect the site from hazardous overvoltage, an overvoltage protection called HVSD (High Voltage Shut Down) is built into every rectifier module. The level is settled as a parameter setting in the monitoring unit.

If the rectifier output voltage exceeds the HVSD level, the rectifier will turn off within about 100 ms. Since the voltage is measured on the "inside" of the blocking diode, the HVSD function is selective, i.e. only the module that is responsible for the overvoltage will trip. Initially, the ALARM-lamp turns on and the ON-lamp will start to flash slowly. With an interval of five seconds, three restart attempts will be performed. If also the third attempt fails, the module will be turned off for good while both the ON- and STBY-lamps are turned off and the ALARM-lamp continues to shine.

Restart after tripped HVSD can be done by keeping the ON-button pressed for at least 5 seconds or by turning off the AC power for a short while. You can also put the module in standby mode by keeping the STBY-button pressed for at least 5 seconds.

4.2.10 Over-/Undervoltage AC

The rectifier module has a built-in self protection that will stop the module when exceeding harmful high or low voltages on the AC power feeding. For trip levels, see section 3.2.1. The module will go back to normal operation as soon as the voltage returns within permissible limits.

4.2.11 External blocking

The rectifier modules can also be turned off remotely via a digital input found on the monitoring unit. The function is called "External blocking". The output voltage will be turned off, the ON-lamp will flash slowly and the STBY-lamp is off. When the blocking condition ceases, the module returns to normal operation.

Even during blocking condition, the module can be turned off "for real" using the STBY-button. In this way the module will remain off when the blocking condition ceases.

4.2.12 Hot swap

Connection of a rectifier module to a DC system during operation (hot swap) is normally not entirely straightforward. Without certain measures you will get a heavy inrush current due to charging of capacitors on the rectifier DC output. Except sparking at the point of connection, you may get a short system voltage drop with possible consequences.

With PRM3, this problem is eliminated due to a built-in output diode that prevents charging of the capacitors from the outside. An extra advantage with the diode is that it eliminates the risk of sinking the whole DC system due to an internal module fault (short circuit). PRM3 modules may consequently without problem be replaced during operation which to a great extent simplifies maintenance and service and will also extend the availability of the DC system.

4.3 FUNCTIONS OF COMPLETE CHARGING RECTIFIER

4.3.1 General

A complete rectifier system of the type PRX3 may, depending on model, hold up to 6 rectifier modules in parallel of the type PRM3.

Here, only the most considerable functions are described. For more information, see *Manual for monitoring unit PCM2*.

4.3.2 Float charging

Float charging is the normal operating mode determined by the battery. The voltage level is to be set according to the battery manufacturer instructions.

For more information, see the *Manual for monitoring unit PCM2*.

4.3.3 Equalizing charging

Equalizing charging means charging with raised voltage level during a limited period. It is used partly for the initial charge, and partly for equalizing cell voltages if spread has occurred.

For more information, see the *Manual for monitoring unit PCM2*.



WARNING: Generally, batteries of VR-type (vent regulated) should not be subject to equalizing charging. For some battery types equalizing charging could even be harmful to the batteries. Always follow the instructions stated by the battery manufacturer.

4.3.4 Battery circuit test

A battery circuit test is automatically carried out at optional intervals (normally once a day). The test involves checking that the entire battery circuit is in working order.

For more information, see the *Manual for monitoring unit PCM2*.

5 OPERATION

5.1 GENERAL

The bulk of the operation is associated to the monitoring unit. This is described in the *Manual for monitoring unit PCM2*. Other operation is detailed in this section.

5.2 RECTIFIER MODULES

5.2.1 General

The front panel of the rectifier module has push-buttons for manoeuvring of the module together with a number of led indication lamps.



5.2.2 Manoeuvre

5.2.2.1 ON

To start the rectifier module, push the ON-button. A green led lamp on the upper left corner of the button tells that the module has started and the orange led lamp by the STBY-button will be put out. DC OK will be put out while ALARM will go red.



If both the ON- and STBY-indications are put out but ALARM is red, the overvoltage protection HVSD may have tripped the module. In this state, it is possible to try a restart by keeping the ON-button pushed for about 5 seconds. Alternatively, you can put the module in standby mode by keeping the STBY-button pressed for at least 5 seconds.

5.2.2.2 STBY (standby)

To stop the rectifier module, push the STBY-button as long as the orange led lamp on the upper left corner of the button is flashing (about 3 seconds). In this way, unintentional shutting off is avoided. When the module is in standby state, the orange STBY-led is put on with steady light while the green ON-led is put out.



If the ON-led is slowly flashing while the STBY-led is off, the output voltage is set to zero as in standby state. The reason might be that the module has remotely been turned off via the function "External blocking" or it may be due to high temperature. Also in this state, it is possible to use the STBY-button to turn off the module "for real".



WARNING: Note that the standby state does not make the equipment dead. For a total dead state, the mains supply and the equipment's DC output must be cut externally. For isolation of individual rectifier modules, the built-in miniature circuit breakers are used.

5.2.3 Indications

5.2.3.1 AC OK

AC OK will be put on with green light if the mains supply is OK.

All indications put out, AC OK included, indicates that there is no mains supply.



AC OK put out while the ALARM-led is red indicates that there is mains supply but not within limits. The DC output is dead. See also section 4.2.10.

5.2.3.2 DC OK

DC OK will be put on with green light if the DC output is OK.

DC OK will be put out if the output voltage is below 50% of nominal voltage. This means that it is also put out in normal standby state.

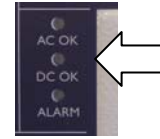

5.2.3.3 ALARM

The ALARM-led is put out in normal operation. Red light indicates a fault condition. Also standby state will give red light, because by the systems point of view it is considered as a fault condition.



The cause of the alarm can be studied in detail using the monitoring unit menu system, see *Manual for monitoring unit PCM2*.

5.2.3.4 CURRENT

The output current of the rectifier module, 0-100%, is shown by a led-bar equipped with 10 yellow led-lamps. I.e. there are one led for each 10:th percent of the rated current.



5.2.3.5 Indication table

Indication					Interpretation
ON	STBY	AC OK	DC OK	ALARM	
Green	Put out	Green	Green	Put out	Normal operation
Green	Put out	Green	Green	Red	1. U _{OUT} low, 50-82% of U _{NOM} 2. I _{OUT} limited due to high temperature 3. Fan fault
Green	Put out	Green	Put out	Red	U _{OUT} low, <50% of U _{NOM}
Green	Put out	Put out	Put out	Red	Mains fault
Flash	Put out	Green	Put out	Red	1. External blocking 2. HVSD tripped, waiting for restart attempt 3. Turned off due to high temperature
Put out	Put out	Green	Put out	Red	Turned off due to tripped HVSD
Put out	Put out	Put out	Put out	Red	Turned off due to tripped HVSD + mains fault
Put out	Orange	Green	Put out	Red	Normal standby
Put out	Orange	Put out	Put out	Red	Mains fault in standby state
Put out	Put out	Put out	Put out	Put out	No mains supply

5.3 MONITORING UNIT PCM2

The operator panel is the visible part of the monitoring unit PCM2. It is composed of a display, push-buttons and a led-lamp. Operation is described in the *Manual for monitoring unit PCM2*.



When measuring the battery voltage you should avoid measuring directly at the battery terminals due to the risk of arcing in the event of a possible short circuit. Use the short-circuit protected voltmeter terminals on the front panel instead. The voltmeter terminal fits a standard 4 mm measuring pin. To avoid measurement errors, the voltmeter used should have high ohms, 10 Mohm or better.

6 INSTALLATION INSTRUCTIONS

6.1 SAFETY INSTRUCTIONS



WARNING! This product contains dangerous voltage that when touched can cause electric shock, burns or death. Protective earth must always be connected in a reliable way to avoid the risk of live parts in the equipment in the event of faults. No live parts are permitted during installation. The product must be installed by qualified personnel (see section 2 [SAFETY INSTRUCTIONS](#)).



WARNING! Check both before and after setting-up that the equipment does not have any mechanical damage. Check that the equipment and individual rectifier modules have the intended rated voltage. Cables for input and output power must be correctly dimensioned to avoid fire hazard.

6.2 GENERAL

Installation of the parts that belong to the monitoring unit are not dealt with in this manual. For complete installation instructions these instructions should therefore be used in combination with the installation instructions included in the *Manual for monitoring unit PCM2*.

Normally, the rectifier modules are not installed by delivery. They are packed separately to be mounted into the rectifier cubicle during installation on site.

6.3 STORAGE AND PROTECTION

Storage is to be in a dry area and at a temperature that does not exceed the -40 to +70 °C range.

6.4 MOUNTING

6.4.1 General

The equipment is intended for placement on floor in a dry, clean environment that is free from conductive dust.



WARNING! Cubicle type F41 has a high center of gravity. Use the enclosed brackets to avoid the risk of tipping.

Cubicle type S39 must with no exception be secured by the wall using the enclosed brackets and/or be bolted to the floor before the rectifier modules are installed to avoid tipping forward when the door is opened!

6.4.2 Erection of cubicle

6.4.2.1 Cubicle type F27

The cubicle has feet that can be adjusted up to 25 mm vertically.

Note that the cubicle has air outlets on the rear why at least 50 mm free space must be left to the wall to ensure sufficient ventilation.

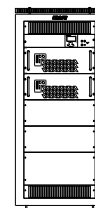

Cable inlet is either from beneath through an opening in the bottom plate (see layout drawing F27 in [Appendix A](#)) or via an FL21 flange through the roof-plate.

6.4.2.2 Cubicle type F41

With rectifier modules installed, the center of gravity of the cubicle will be high. As a consequence, the upper part of the cubicle must be secured to the wall. Use the enclosed brackets, see layout drawing F41 in [Appendix B](#). Also leave at least 50 mm free space to the wall to ensure sufficient ventilation.

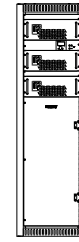

For maximum safety it is recommended that the enclosure is also bolted to the floor according to the layout drawing F41.

Cable inlet is primarily from the floor through the opening in the bottom of the enclosure. Alternatively, the inlet can be done through the detachable roof plate. In that case, be careful to maintain the environmental protection class.

6.4.2.3 Cubicle type S39

To eliminate the risk of tipping forward when the door is opened, the cabinet **must**, with no exception, be secured to the wall by using the enclosed brackets and/or be bolted to the floor before the rectifier modules are installed. Also leave at least 100 mm free space to the wall to ensure sufficient ventilation, see layout drawing S39 in [Appendix C](#). The brackets are bolted on the top of the cubicle using holes aimed for lifting lugs.

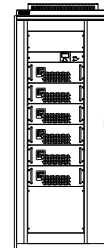

Cable inlet is primarily from the floor through the opening in the bottom of the enclosure. As an option a roof-plate equipped with a number of FL21 flange openings is available.

6.4.3 Mounting of rectifier modules

6.4.3.1 General

The mounting of the rectifier modules can with advantage wait until the electrical installation is finished. Check with the modules rating plate that the rated voltage corresponds to the nominal voltage of the battery.



WARNING! *The equipment may cause personal injury or damage to property if dropped. Use secure lifting aids where appropriate.*

6.4.3.2 Cubicle type F27 and F41

Connect the following cable sets to corresponding connectors on the rear of the module:

1. Connect the 4-pole cable set with connector housing marked –X11 to the connector marked L1/L2/L3/PE on the module T1. In the same way, connect cable set marked –X12 to module T2 and so on.
2. Connect the 2-pole cable set with connector housing marked –X31a to one of the two connectors marked L+/L- on the module T1. In the same way, connect cable set marked –X32a to module T2 and so on.
3. For modules with a rated voltage of 110V or 220V, a second 2-pole cable set with connector housing marked –X31b should be connected to the other of the two connectors marked L+/L- on the module T1. In the same way, connect cable set marked –X32b to

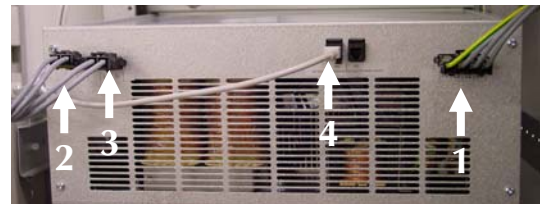

module T2 and so on.

4. Connect the RJ45 cable (network cable) with contact housing marked 1 to socket –X4 on the module T1. In the same way, the RJ45 cable with contact housing marked 2 is connected to module T2 and so on.

Push the module into its slot position while the cable sets are lead in behind the shelf without getting jammed. Fasten the modules onto the rack frame using the four holes on the short sides of the module.

6.4.3.3 Cubicle type S39



DANGER! Before mounting of the modules into the door slots, the risk of tipping must be eliminated by securing the cubicle to the wall using the enclosed brackets and/or bolting to the floor!

Push the modules into its door slot positions.

Fasten the modules with four screws onto the rack frame using the holes on the short sides of the module.

6.5 ELECTRICAL INSTALLATION

6.5.1 General

PRX3 is designed for permanent installation only. Protective earth must be connected before any other installation.

6.5.2 Grounding

For ground wire connections up to 10 mm² the multi-pole brass connector is used.

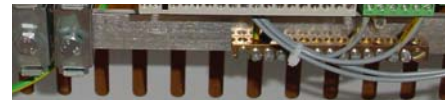

For incoming AC power in cubicle F41 and F39, there is connection clamps on the main grounding bar while a ground screw terminal is available in cubicle F27.

Connection of an equipotential earth bonding may be done via a connection clamp on the main grounding bar in cubicle F41 and S39 and via an M8 bolt located on the main grounding bar in cubicle F27 (see picture).

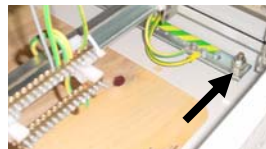

6.5.3 Mains voltage

Select external mains fuse rating according to the table in section 3 [ASSORTMENT](#).

Connect 3-phase mains power to terminal X10:1, 2 and 3. The picture shows an example from cubicle S39. The phase sequence is of no consequence. The ground wire is connected according to the previous section.



Note that PRX3 is intended exclusively for TN earthing system network.

Unique for cubicle S39 with 440V rated DC voltage and four or more rectifier modules, is that 230V AC auxiliary power has to be supplied to terminal X10:4 and 5. It is power for the AC/DC converter T7 used to create internal auxiliary power.

6.5.4 DC power output

Check that the rating plate of the cubical shows a rated voltage that conforms with the battery's nominal voltage.

Connect the DC system to the terminals marked L- and L+. Use cables that are dimensioned for handling the rectifier's rated output current and the closest following fuse. The picture shows an example from cubicle S39 with doubled terminals aimed for higher currents.



6.5.5 I/O unit

All the connections to the monitoring units are grouped in a unit called the I/O unit. The connectors are pluggable, i.e. they can be removed for better accessibility when installing. For more information about these connections, see *Manual for monitoring unit PCM2*.



On the I/O unit, auxiliary power is connected to X5:1(-) and X5:2(+) while measuring voltage is connected to X7:3(-) and X7:5(+) according to the *Manual for monitoring unit PCM2*. An exception is cubical S39 equipped with four or more rectifier modules. In that case the auxiliary power is connected to the cubicle terminals X31:1(-) and X31:2(+) since X5 on the I/O unit is already occupied.

6.5.6 Rectifier modules

6.5.6.1 Cubicle type F27 and F41

By this time, the rectifier modules should have all cable sets connected on the rear of the module (see section 6.4.3.2) and the other end of the cable sets should hang down on the inside of the cubicle visible from the front.

Connect the 4-pole connector for AC with housing marked -X111 to corresponding connector on the connector plate. In case of more modules, do similar with housing marked -X112 and -X113.



Connect the 2-pole connector for DC with housing marked -X131a to corresponding connector on the connector plate. In case of more modules, do similar with housing marked -X132a and -X133a. For DC voltage ratings 110V and 220V there are also -X131b, -X132b and -X133b.



Connect the RJ45 cable (network cable) marked 1 to socket number 1 on the hub-board (right up to the left). In case of more modules, continue with cable number 2 to socket number 2 and cable number 3 to socket number 3.



Hub board

6.5.6.2 Cubicle type S39

Connect the following cable sets to corresponding connectors on the rear of the module:

1. Connect the 4-pole cable set with connector housing marked –X11 to the connector marked L1/L2/L3/PE on the module T1. In the same way, connect cable set marked –X12 to module T2 and so on.

2. Connect the 2-pole cable set with connector housing marked –X31a to one of the two connectors marked L+/L- on the module T1. In the same way, connect cable set marked –X32a to module T2 and so on.



3. For modules with rated a voltage of 110V or 220V, a second 2-pole cable set with connector housing marked –X31b should be connected to the other of the two connectors marked L+/L- on the module T1. In the same way, connect cable set marked –X32b to module T2 and so on.
4. Connect the RJ45 cable (network cable) with contact housing marked 1 to socket X4 on the module T1. In the same way, the RJ45 cable with contact housing marked 2 is connected to module T2 and so on.

7 COMMISSIONING

7.1 SAFETY INSTRUCTIONS



DANGER! *This product contains dangerous voltages that when touched can cause electric shock, burns or death. All contact safety devices and plates must be fitted when operating. Ensure that the apparatus has been in a dead condition for at least 5 minutes before any protective coverings are removed, giving the internal circuits time to discharge.*

7.2 PREPARATORY INSPECTION

Check that the equipment is free from damage, correctly fitted and that all the ventilation openings are free from obstacles.

Check that all cable installations, electrical connections and protective earths are correctly implemented.

Check that all protective covers are intact and all breakers and fuses are switched off.

Check that the rating plate of the cubical shows a rated voltage that conforms to the battery's nominal voltage and the rated voltage of the entire DC system.

7.3 POWERING UP

7.3.1 DC

First, provide power to the measuring circuit and the auxiliary input power of the monitoring unit by, for example, connecting a fuse in the battery circuit.

After a few seconds, the operator panel display lights up, and after a few more seconds text appears on the display. All measurement values are initially reset. The measurement starts after around 10 seconds. Alarms are disabled during the initial 30 seconds.

Then connect the rectifier to the battery by, for example, connecting a fuse in the battery circuit.

Switch on the DC output MCB for each rectifier module (F31 for module T1, F32 for module T2, etc).

7.3.2 AC

Unique for cubicle S39 with 440V rated DC voltage and four or more rectifier modules is that the 230V AC auxiliary power feeding should be switched on first.

Turn on mains input power.

Switch on the AC input MCB for each rectifier module (F11 for module T1, F12 for module T2, etc).

After a 5-10 seconds delay, the rectifier modules will start, but most likely in standby mode (depending on the condition when they were last turned off). Start the modules one by one in raising order by pushing the ON-button.

The battery now starts to charge, and if it was in a state of deep discharge, the charging starts with rated current until the float charging level is reached. Certain types of battery require an initial equalizing charging. Always follow the recommendations stated by the battery manufacturer.

7.4 CHECKING THE CHARGING VOLTAGE

Check the settings of the monitoring unit to ensure that the voltage level for float charging and equalizing charging conform to the battery manufacturer's specification, see *Manual for monitoring unit PCM2*.

When the battery is charged to a level where the "High current" alarm is no longer active, you should check that the actual output voltage conforms to the setting of the float charging voltage, see section 8.1.2 [Checking the charging voltage](#).

7.5 CHECKING THE SETTINGS

Each time the monitoring unit has been powered down, the built-in clock must be reset with the current date and time, see the *Manual for monitoring unit PCM2*.

Check that the measurements shown on the display agrees with the actual situation. Check that the parameters for charging voltages, alarms and other parameters conforms to the intended functions, see the *Manual for monitoring unit PCM2*.

7.6 CHECKING THE OUTPUTS

The alarm outputs A-D and the output for fan control can be operated manually for simple and smooth check-up of external circuits, see *the Manual for monitoring unit PCM2*.

8 MAINTENANCE

8.1 ANNUAL INSPECTION

8.1.1 General

In addition to these instructions, you must observe the instructions for maintenance in the *Manual for monitoring unit PCM2* and the battery manufacturer's maintenance instructions.

8.1.2 Checking the charging voltage

Connect a voltmeter to the test contacts (see section 5.3 [MONITORING UNIT PCM2](#)). Check that the rectifier's output voltage corresponds to the setting of the float charging level.

If the float charging voltage is temperature controlled, it is difficult to determine the expected output voltage. The solution is to temporarily shut down the temperature control. You do this using the menu option *Functions, battery temperature* to specify that the temperature sensor is not installed (see the *Manual for monitoring unit PCM2*, section *Operation, Functions*). Do not forget to reset the parameter for the installed temperature sensor following the completed measurement!

All control is based on measurement. If charge voltage is found to be in a state of non-conformance it is therefore the voltage measurement that should be calibrated, see the instructions for maintenance in the *Manual for monitoring unit PCM2*.

8.1.3 Checking the cooling capacity

Check that the rectifier modules' ventilation vents are not clogged with dust or other contaminants. Clean where necessary.

9 FAULT TRACING AND SERVICE

9.1 SAFETY INSTRUCTIONS



DANGER! This product contains dangerous voltages that when touched can cause electric shock, burns or death.

Ensure that the apparatus has been in a dead condition for at least 5 minutes before any action, giving the internal circuits time to discharge.

Service/maintenance work in the apparatus may only be carried out by authorised service personnel (see section 2 [SAFETY INSTRUCTIONS](#)).

9.2 FAULT TRACING ALARMS

Fault tracing in connection with alarm messages is described in the *Manual for monitoring unit PCM2*.

9.3 OTHER FAULT TRACING

The types of faults that can be attributed to the system in general are dealt with here. For faults that relate to the monitoring unit see the *Manual for monitoring unit PCM2*.

The external primary fuse trips when the rectifier is turned on

Cause 1: Wrong type of external primary fuse. Check that the system is properly fused according to the instructions in section 3.

Cause 2: Internal fault in a rectifier module. Replace the defective module.

Internal primary MCB trips when a rectifier module is switched on

Cause 1: Internal fault in a rectifier module. Replace the defective module.

The rectifier has no output, green indicator lamp "AC OK" is off on all rectifier modules

Cause 1: No mains power. Check that there is mains voltage to the mains input terminals.

Cause 2: If the red lamp ALARM is lit as well, the modules have been turned off due to high or low mains voltage. The modules will regain normal operation as soon as the mains voltage returns to a proper level.

Green indicator lamp "AC OK" is off on a single rectifier module

Cause 1: Internal primary MCB has tripped, see above.

Cause 2: AC power connector not properly connected to the module.

Cause 3: If the red lamp ALARM is lit as well, the modules have been turned off due to high or low mains voltage. The module will regain normal operation as soon as the mains voltage returns to a proper level.

The monitoring unit gives the alarm "Fuse fault"

Cause 1: Internal DC output MCB has tripped. Probably due to an internal fault in a rectifier module. Replace the defective module.

The rectifier module's green indicator lamp "AC OK" is lit and "DC OK" is off

Cause 1: The rectifier module is in standby mode which is a normal condition.

Cause 2: The input "EXT. FAULT" is used as external blocking and is in open state. Only valid if all modules shares the same symptom.

Cause 3: The rectifier module has tripped due to overvoltage on the DC output (HVSD). The module may need to be replaced.

- Cause 4: The rectifier module has tripped due to high temperature. Wait until it has cooled off and it will start by itself.
- Cause 5: The rectifier module might be defective. Try to replace it.

The rectifier module's red indicator lamp "ALARM" is lit

- Cause 1: If the cause is not obvious, e.g. due to the former presented alternatives, you can use the monitoring unit display to show the status of the rectifier modules in detail, see the *Manual for monitoring unit PCM2*.

The rectifier output voltage is too low

- Cause 1: The rectifier load is greater than its capacity (rated current). This is a normal condition during recharging following a deep discharge.
- Cause 2: A battery circuit test is in progress. This is a test that is normally executed automatically once a day.
- Cause 3: The selected charging voltage (float charge or equalization charge) is close to or greater than the limit for parameter U_{maximum} . The output voltage cannot exceed $(U_{\text{maximum}} - 1\%)$. If a higher charging voltage is required, the value of U_{maximum} must be increased, see *Manual for monitoring unit PCM2*.
- Cause 4: High temperature in battery/battery room. Only applicable if the parameter settings allow temperature regulation of the float charging voltage. In this case, there is no fault related to the rectifier. Look for the fault related to the high temperature instead. Alternatively the temperature sensor could be defective. Check whether the display is reporting the correct battery temperature.
- Cause 5: Incorrect float charging voltage level setting. Adjust the setting.
- Cause 6: Incorrectly calibrated voltage measurement. Recalibrate the monitoring unit's measurement of battery voltage.
- Cause 7: The current is internally limited due to high internal temperature or internal power limitation.

The rectifier output voltage is too high

- Cause 1: Equalization charging in progress. This has either been initiated manually or automatically following a power failure.
- Cause 2: Low temperature in battery/battery room. Only applicable if the parameter settings allow temperature regulation of the float charging voltage. In this case, there is no fault related to the rectifier. Look for the fault related to the low temperature instead. Alternatively the temperature sensor could be defective. Check whether the display is reporting the correct battery temperature.
- Cause 3: Incorrect float charging voltage level setting. Adjust the setting.
- Cause 4: Incorrectly calibrated voltage measurement. Recalibrate the monitoring unit's measurement of battery voltage.

Rectifier modules does not share the load equally

- Cause 1: The current is too high/low to be in the range where active loadsharing is in operation. The loadsharing is active in the range of about 10-90 % of rated current.
- Cause 2: Some fault conditions, like for instance communication fault or first module out of operation, will stop active loadsharing.

9.4 INSTRUCTIONS FOR REPLACING RECTIFIER MODULE DURING OPERATION (HOT SWAP)

It is possible to replace a single rectifier module while the other still are in operation. The method is slightly different depending on type of cubicle.



WARNING! *The equipment may cause personal injury or damage to property if dropped. Use secure lifting aids where appropriate.*

9.4.1 Enclosure type F27 and F41

Begin with turning off the AC input power for the module by switching off the corresponding MCB (F11 for module T1, F12 for module T2, etc.)

Also turn off the DC output power for the module by switching off the corresponding MCB (F31 for module T1, F32 for module T2, etc.)

Locate the 4-pole contact housing on the left side of the contact plate. For rectifier module T1 it is marked -X111, for rectifier module T2 it is marked -X112, etc. Pull out the upper part of the contact.



Locate the 2-pole contact housing on the right side of the contact plate. For rectifier module T1 it is marked -X131, for rectifier module T2 it is marked -X132, etc. For the rated DC voltages 110V and 220V, they are in addition doubled, i.e. -X131a and -X131b, etc. Pull out the upper part of the contacts.

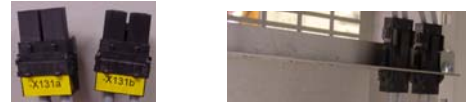

Locate the hub-board. Pull out the RJ45 cable that corresponds to the module in question. Socket No. 1 corresponds to T1, Socket No. 2 corresponds to T2, etc.



Hub board

Loosen the four screws on the short sides of the front of the module. Pull out the module while carefully seeing to that the cable sets follows gently without getting jammed on the way.

Move all cable sets from the rear of the old module to corresponding positions on the new module.

Push the module into its slot position while the cable sets are lead in behind the shelf without getting jammed. Fasten the module by restoring the four screws.



Connect the cable sets as they where before.

Switch on the AC input power MCB, then the DC output MCB.

The module is now ready to be started by using the buttons on the front panel.

9.4.2 Enclosure type S39

Begin with turning off the AC input power for the module by switching off the corresponding MCB (F11 for module T1, F12 for module T2, etc.)

Also turn off the DC output power for the module by switching off the corresponding MCB (F31 for module T1, F32 for module T2, etc.)

Pull out all cable sets from the rear of the module.

Loosen the four screws on the short sides of the front of the module and pull out the module.



Push in the new module and fasten it by restoring the four screws.

Connect the cable sets as they where before.

Switch on the AC input power MCB, then the DC output MCB.

The module is now ready to be started by using the buttons on the front panel.

Appendix B LAYOUT AND DIMENSION DIAGRAM PRX3, CUBICLE TYPE F41

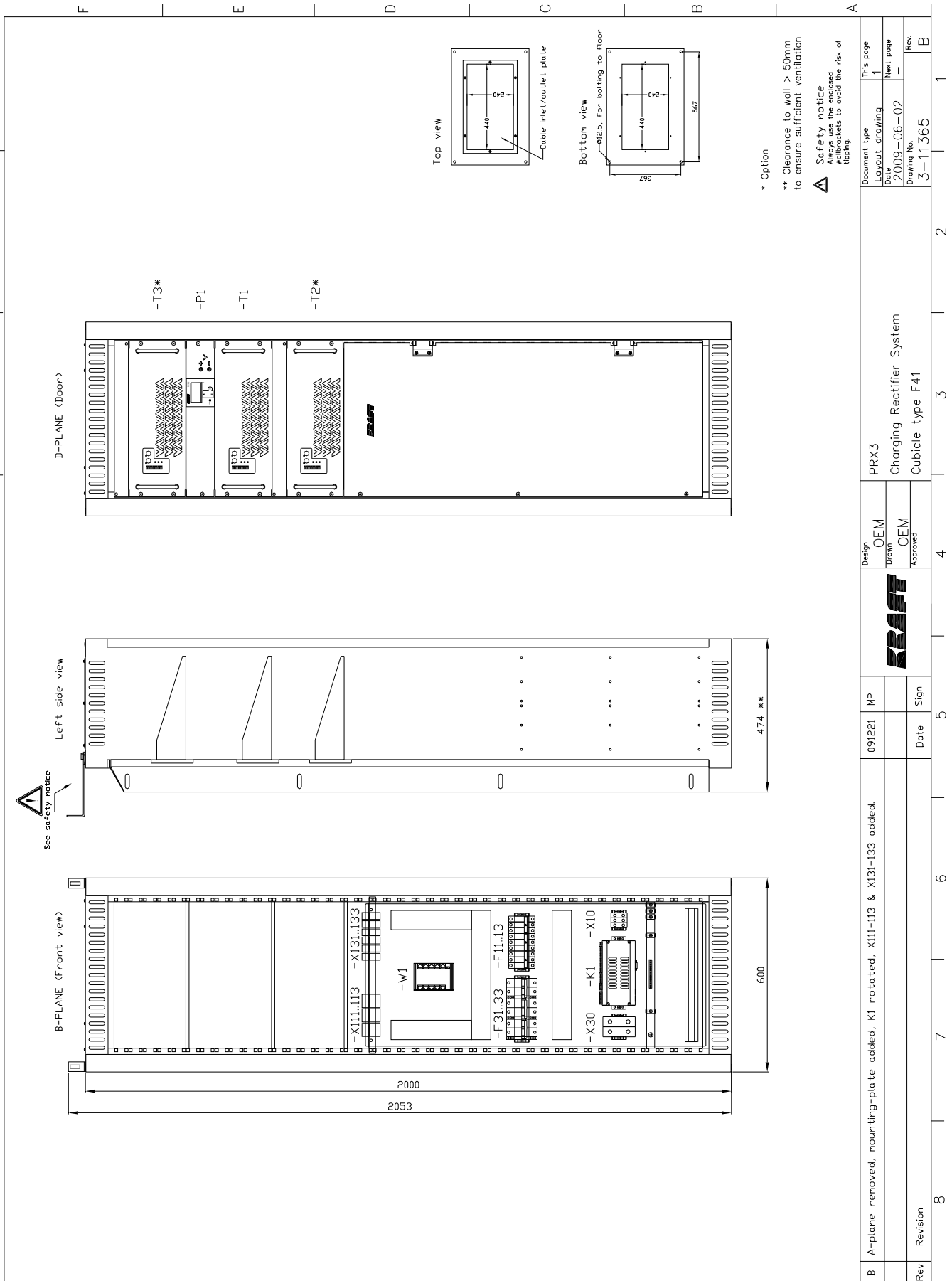

B	A-plane removed, mounting-plate added, K1 rotated, X111-113 & X131-133 added.	09 221	MP		Design	OEM	PRX3	Document type	This page	1	
					Drawn	OEM	Charging Rectifier System	Layout drawing	Next page	1	
Rev	Revision	Date	Sign		Approved	Cubicle type F41		Date	2009-06-02	Next page	1
								Drawing No.	3-11365	Rev.	B

Appendix C LAYOUT AND DIMENSION DIAGRAM PRX3, CUBICLE TYPE S39

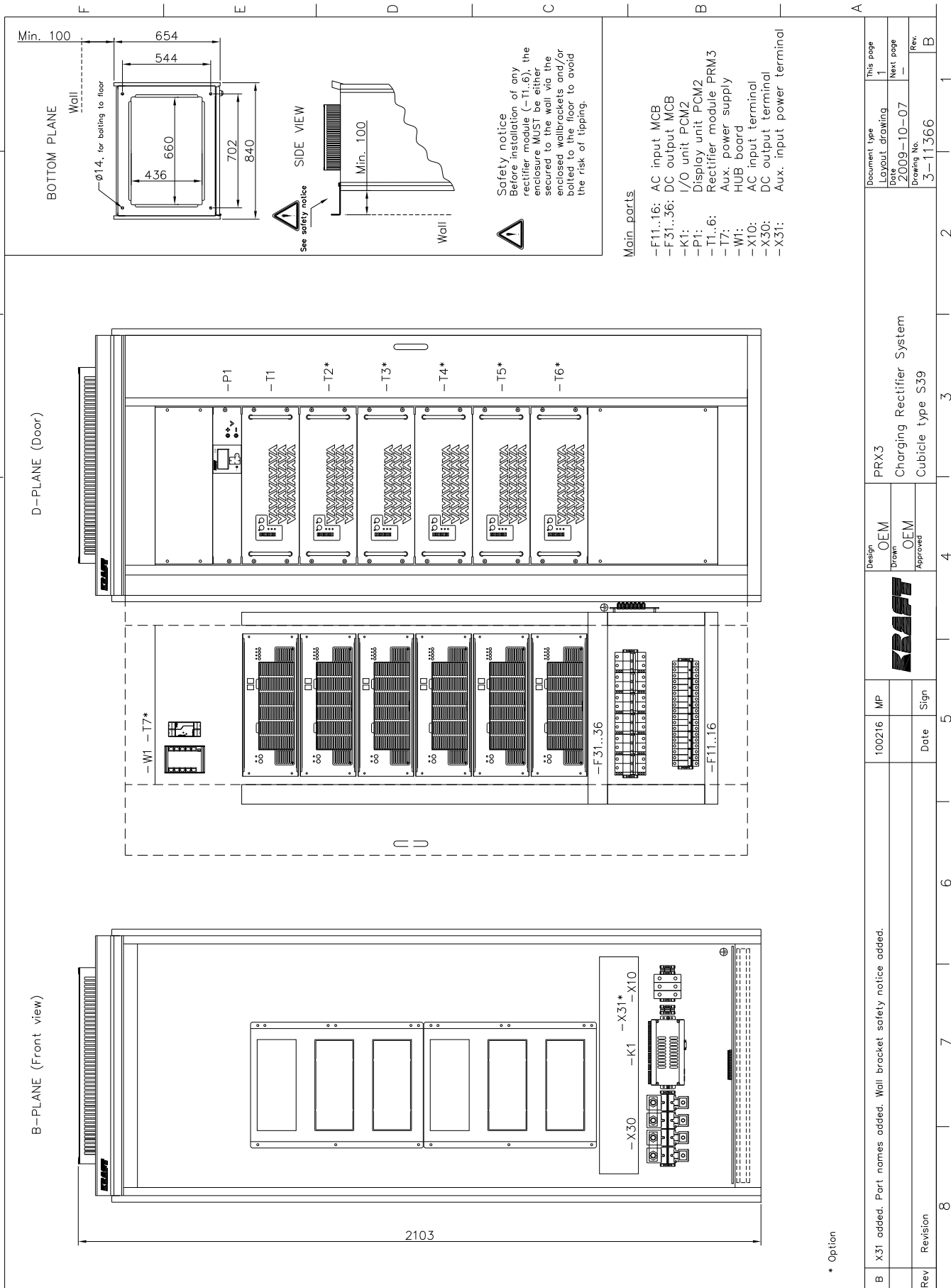

* Option

Appendix D
DIMENSION DIAGRAM RECTIFIER MODULE PRM3

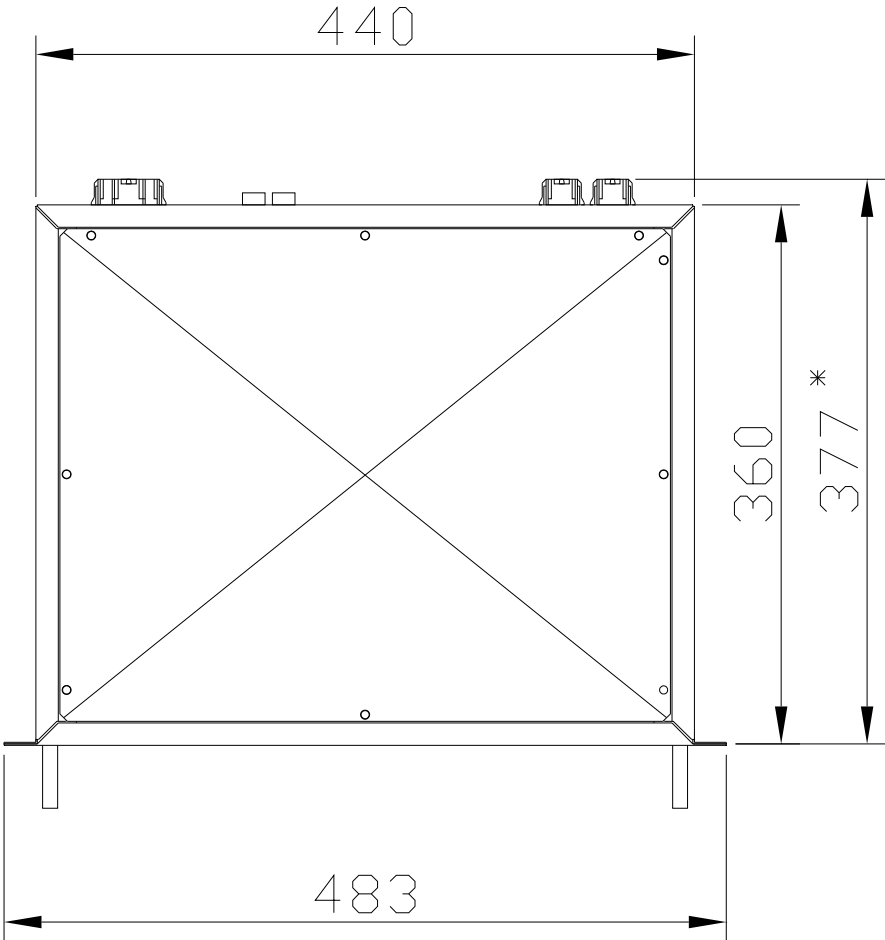
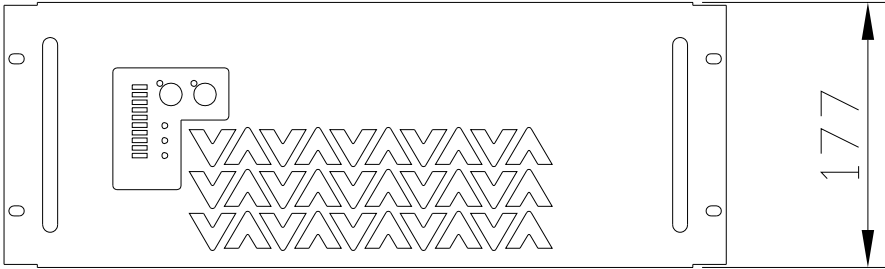

* In addition ~30 mm for plug connector and wires

Appendix E CIRCUIT DIAGRAM PRX3

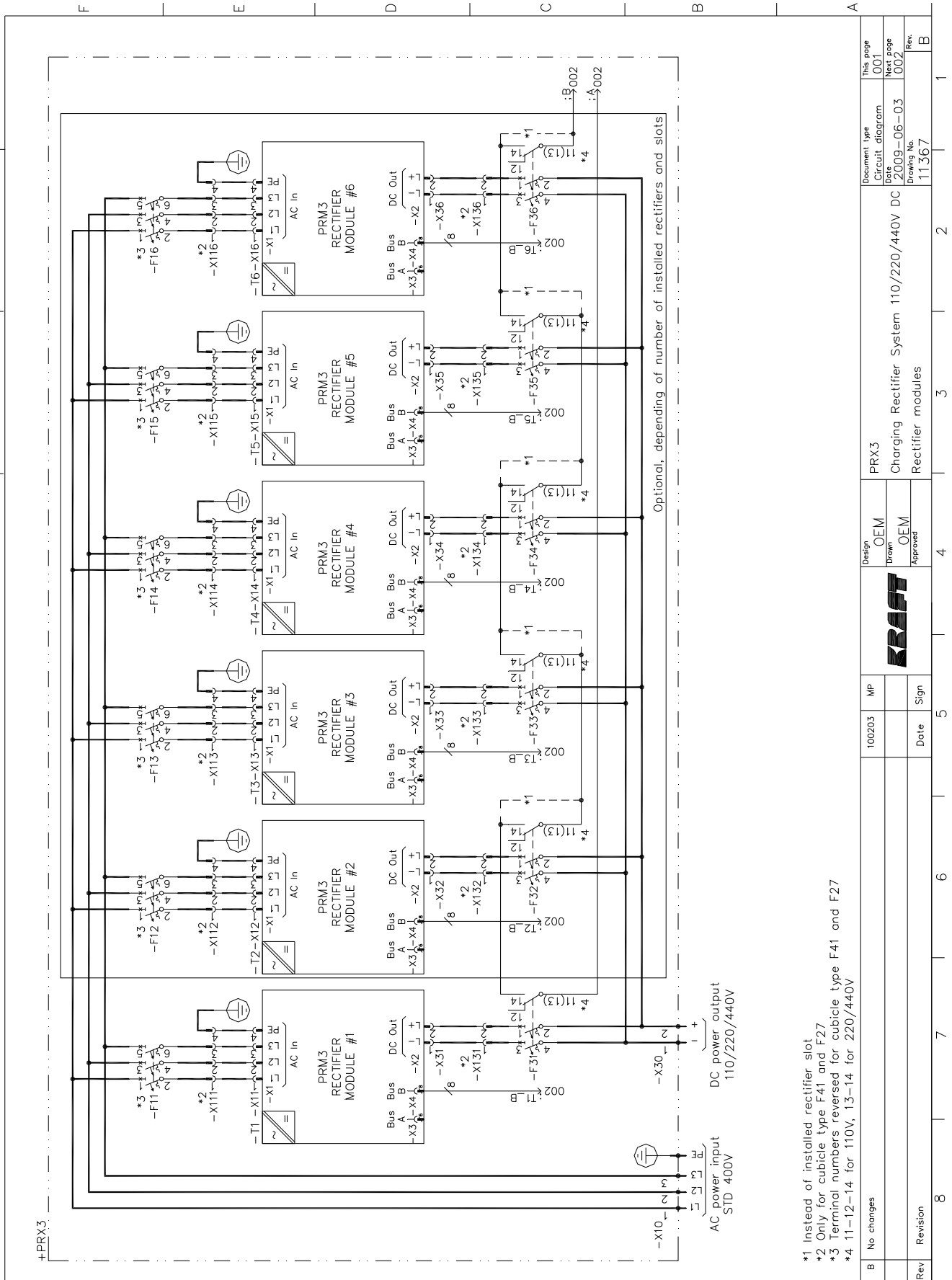

We reserve all rights in this document and in the information
 contained herein. Reproduction, use or disclosure to third
 parties without express authority is strictly forbidden.
 © Kraftelektronik AB

- *1 Instead of installed rectifier slot
- *2 Only for cubicle type F41 and F27
- *3 Terminal numbers reversed for cubicle type F41 and F27
- *4 11-12-14 for 110V, 13-14 for 220/440V

B	No changes	100203	MP		Design	OEM	PRX3	Document type	This page
					Transm	Approved		Charging Rectifier System 110/220/440V DC	Circuit diagram
Rev	Revision	Date	Sign					Date	Next page
								2009-06-03	002
								Drawing No.	Rev.
								11367	B

Appendix F CIRCUIT DIAGRAM RECTIFIER MODULE PRM3

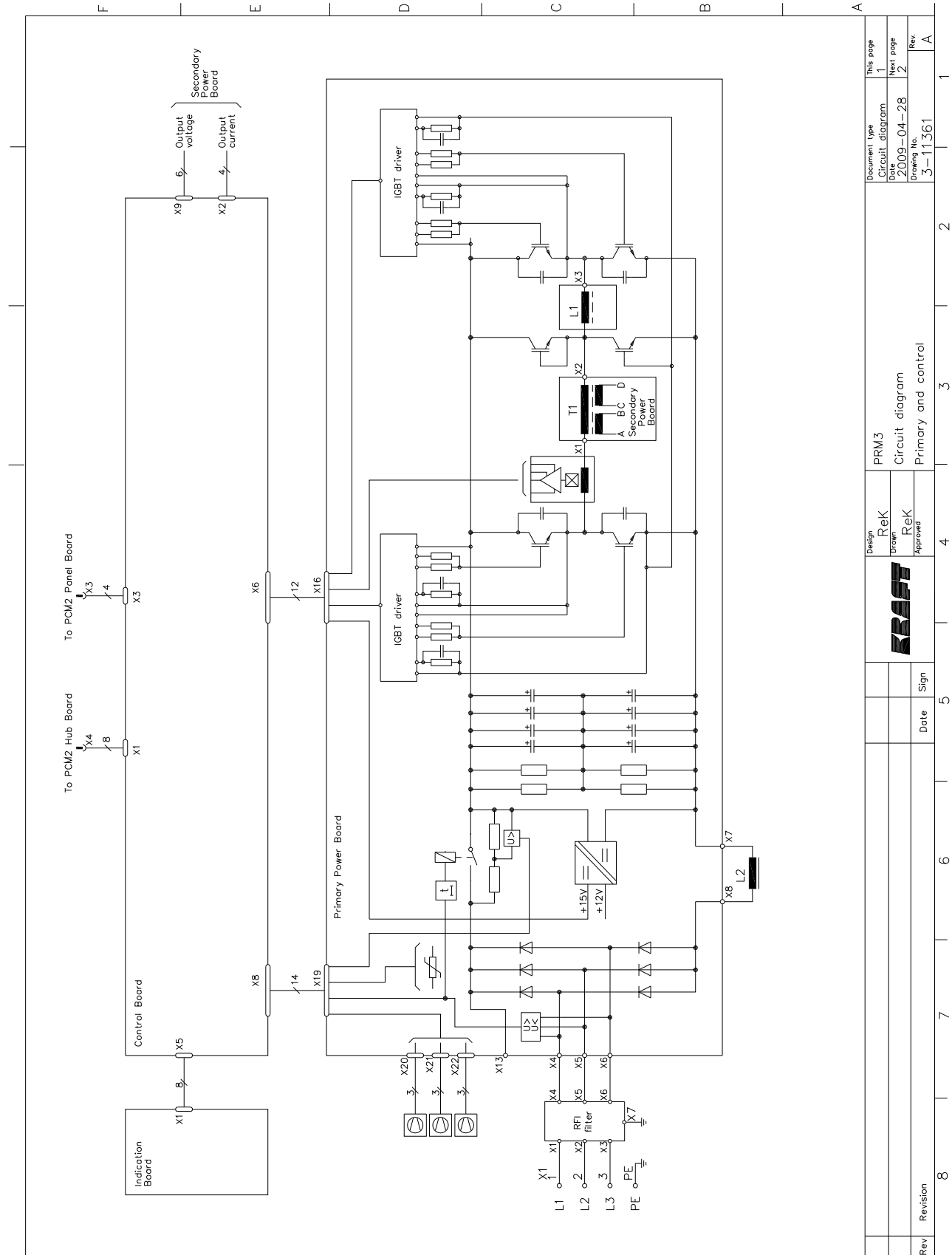

We reserve all rights in this document and in the information contained herein. Reproduction, use or disclosure to third parties without express authority is strictly forbidden.
© Kraftelektronik AB

Rev	Revision	Date	Sign	Design	PRM3	Document type	This page
				Rek Drawn	Circuit diagram	Circuit diagram	1
				Rek Approved	Primary and control	Date	Next page
						2009-04-28	2
						Drawing No.	Rev.
						3-11361	A

We reserve all rights in this document and in the information contained therein. Reproduction, use or disclosure to third parties without express authority is strictly forbidden.
 © Kraftelektronik AB

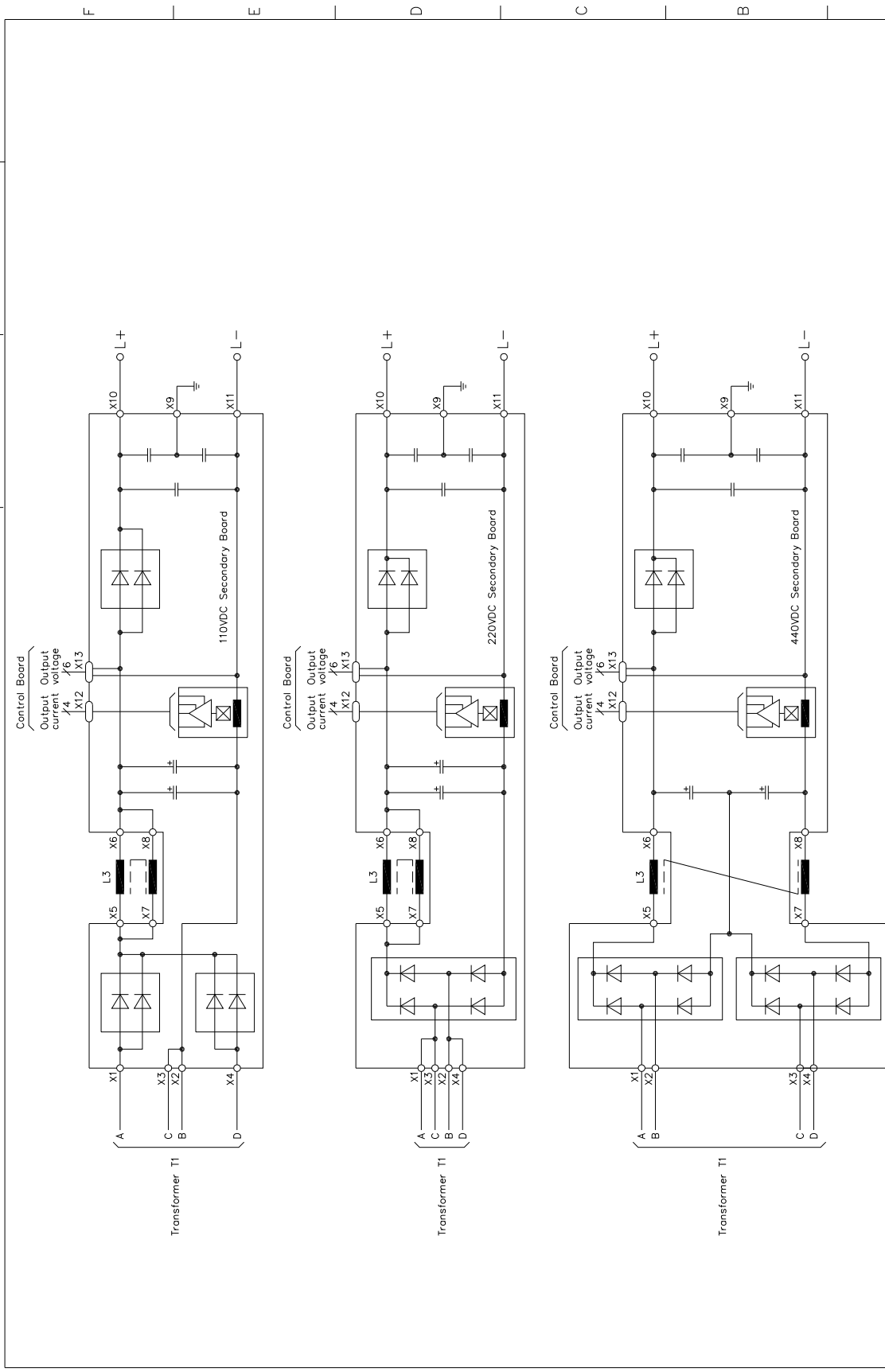

Rev	Revision	8	7	6	5	4	3	2	1	
		Date	Sign	PRM3		Circuit diagram		Document type	This page	
				Design	Rek	Rek	Rek	Rek	Circuit diagram	2
				Drawn	Rek	Rek	Rek	Rek	Date	Next page
								2009-04-28	2	
								3-11361	1	
									Rev.	
									A	

